

# Direct Insert Type Level Switches



## Features

- Float level switch with application upto 60 bar and 350 deg cent application
- Heavy walled floats for critical application
- Tight sealing versions for float sensors with switch to enable correct application solutions, with sealing internals at 10(-3/-4) mbar ltr / sec available
- Insertion length defined for 3000mm
- Switching differential upto 2mm
- Durability defined on sealing and pressure and temperature application
- Improved reliability with dual opposed magnet design which provides snap action
- Applicable with various versions of MOC's depending on pressure and temperature, versions with Stainless and steel, Hastelloy, monel, PTFE, PP, Titanium available
- Special magnet attractor to meet high temperature and pressure
- Versions with flange, screwed, welded available
- Applicable for H2S, NACE, certified
- Switch is CCOE approved and certified for IP67
- Switch certified for group IIA/IIB, IIC
- Switch enclosure at die cast aluminium and SS available
- Application with PTFE lined at special 1.6 mm thickness and PTFE floats for critical media available
- Versions with ATEX and FM certified available

## Concept and Principle of Operation

Direct insert or direct mounted level switch uses the counterbalance principle. It consists of float and float stem with counterbalance weight and switch mechanism with magnet attractor.

In this type there are two versions applicable:

- Direct insert side mounted LS1000-SM
- Direct insert top mounted LS1000-MT

### LS1000-SM: Side Mounted direct insert mounted level switch

#### Principle of operation:

In this type of Level Switch Float held in horizontal position and moves upwards and downwards with rising and falling level in the tank / vessel. This movement results in a rotary motion of the attractor causes actuation of microswitch. To improve reliability it employs dual opposed magnet design which provides snap action.

## Application

This type of level switch is mounted directly on the tank / vessel having horizontal nozzle as shown in figure. The tank / vessel connection must be located at the elevation where set level is to occur. Applications are suitable in cryo tanks and applications for high temperature with special material are also applicable



Exproof IIC version for LS1000-SM



Weather proof version of LS1000-SM

## Direct Insert Type Level Switches



### LS 1000: Top Mounted Direct Insert Mounted Level Switch

This is direct mounted type level switch. This provides contact changeover at a selected elevation level in the tank / vessel. Switch is mounted on top of the tank / vessel and coupled with float assembly rides on the liquid surface with rising and falling of level. The magnet attractor is connected on the isolating tube as shown in figure. As the level rises stem head of float assembly reaches upto attractor causes actuation of microswitch. To improve reliability the stem guide isolated just above the float. This type of level switch issued for lengths upto 3000mm.



Exproof IIC version for LS1000MT



Weather proof version of top mounted LS1000MT

### Technical Specifications: Table-1 Technical data

<b>Type</b>	Direct Insert Type
<b>Mounting</b>	Side Mounted / Top Mounted
<b>Switch Housing</b>	Die Cast Aluminium Weatherproof to IP-67 Die Cast Aluminium Explosionproof suitable for Gr. IIA, IIB Die Cast Aluminium Explosionproof suitable for Gr. IIC
<b>Switch Type</b>	Snap Acting 1SPDT / 2SPDT Microswitch, 5A, 230VAC / 0.5A, 24VDC
<b>Cable Entry</b>	1 no / 2 nos. of 3/4"ET(F), 1/2"NPT(F), M20x1.5(F)
<b>Process Connection</b>	Flanged in various sizes
<b>Flange MOC</b>	SS304, SS316, SS316L, Monel400, Titanium, Inconel 600, Hastelloy-C Others on request
<b>Float/Stem MOC</b>	SS304, SS304L, SS316, SS316L, Monel400, Titanium, Inconel 600, Hastelloy-C Others on request
<b>Specific gravity</b>	Please specify
<b>Pressure</b>	Up to 100kg/cm <sup>2</sup> g
<b>Temperature</b>	(-100) to 350°C
<b>Switch certification</b>	CCOE, FM, ATEX, CE (Versions applicability on request)

# Direct Insert Type Level Switches

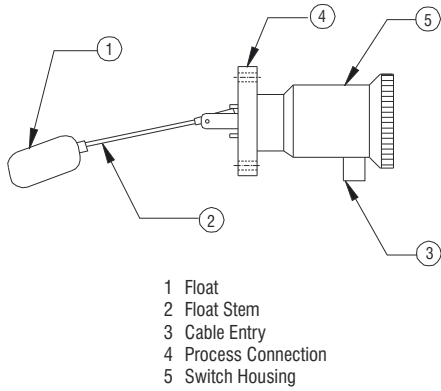

Side mounted direct insert level switch

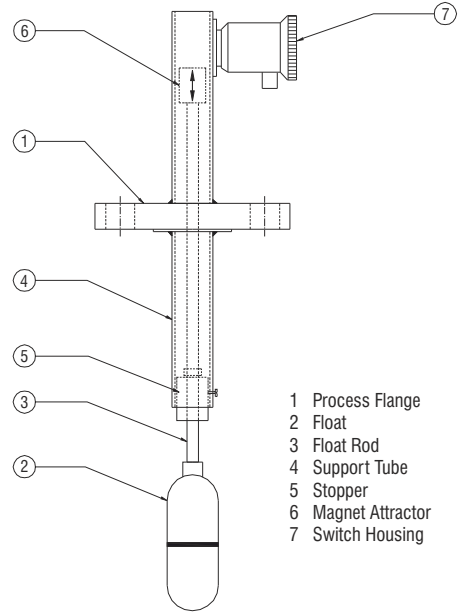

Top mounted direct insert level switch

## G A Drawing for assembly and mounting

## Ordering Information

**LS1000 SM-F05-ZC-RA-SI-PU-MQ**



Model	
Direct Insert Type Level Switch	LS1000

Type	
SM	Side Mounted
MT	Top Mounted

Process Connection	
Flanged Connection	
F05	2", 150# RF
F06	2.5", 150# RF
F13	2", 300# RF
F14	2.5", 300# RF
XX	Any Other

MOC of Connection			
ZC	SS 304	ZK	Monel 500
ZD	SS 304L	ZM	Hastelloy-B
ZE	SS 316	ZN	Hastelloy-C
ZF	SS 316L	ZO	Inconel 600

Cable Entry	
MQ	One
MR	Two

Enclosure	
PU	Die Cast Aluminium Weatherproof to IP - 67
PV	Die Cast Aluminium Flameproof suitable to Gr. IIA / IIB
PW	Die Cast Aluminium Flameproof suitable to Gr. IIC

Microswitch	
SI	1 SPDT
SJ	2 SPDT

MOC of Float Assembly			
RA	SS 304	RF	Monel 500
RB	SS 304L	RG	Hastelloy-B
RC	SS 316	RH	Hastelloy-C
RD	SS 316L	RI	Inconel 600

# Displacer Type Level Switches



## Features

- Level Switch with application upto 40 bar and 250 deg cent application
- Heavy walled level sensor for critical application
- Insertion length defined for 10000mm
- Switching differential upto 10mm
- Durability defined on sealing and pressure and temperature application
- Improved reliability with dual opposed magnet design which provides snap action
- Applicable with various versions of MOC's depending on pressure and temperature, versions with Stainless and steel, hastelloy, monel, PTFE, PP, Titanium available
- Versions with flange, screwed, welded available
- Applicable for 2S, NACE, certified
- Switch is CCOE approved and certified for IP67
- Switch certified for group IIA/IIB, IIC
- Switch enclosure at die cast alluminium and SS available
- Application with PTFE lined at special 1.6 mm thickness and PTFE floats for critical media available
- Versions with ATEX and FM certified available



## Concept and Principle of Operation

*General* offers Top Mounted Sensor Operated Level Switches for single and multiple level set points:

### Series TMLS/3000

This is top mounted type level switch provided single or multiple set points. It uses Level sensor that do float on the surface of liquids with certain immersed section with respect to design. Working principle of the level switch is based on a buoyancy principle.

This level switch is consists of Switch Assembly, Wire Rope with Spring Assembly and level sensor suspended on spring. Level sensor having more density than the process liquid is used. Spring selection is determined by the weight of the level sensor. When level rises it the level sensor is submerged as per the design consideration and amount of weight equal to the weight of process liquid is displaced. This displacement relieves the spring tension which is related to tension constant R, causes the actuation of microswitch. This type of level switch is used for lengths upto 10000 mm.

## Technical Specifications: Table-1 Technical Data

<b>Type</b>	Displacer Operated Level Switch
<b>Mounting</b>	Top Mounted
<b>Switch Housing</b>	Die Cast Aluminium Weatherproof to IP-67 Die Cast Aluminium Explosionproof suitable for Gr. IIA, IIB Die Cast Aluminium Explosionproof suitable for Gr. IIC
<b>Switch Type</b>	Snap Acting 1SPDT/2SPDT Microswitch, 5A, 230VAC /0.5A, 24VDC
<b>Cable Entry</b>	1 no / 2 nos. of 3/4"ET(F), 1/2"NPT(F), M20x1.5(F)
<b>Process Connection</b>	Flanged in various sizes
<b>Flange MOC</b>	CS,SS304, SS316, SS316L, PP Other on request
<b>Displacer MOC</b>	SS304, SS304L, SS316, SS316L, PP Other on request
<b>Wire Rope MOC</b>	SS304, SS304L, SS316, SS316L, PP Other on request
<b>Spring MOC</b>	SS304, SS304L, SS316, SS316L, PP Other on request
<b>Specific gravity</b>	Please specify
<b>Pressure</b>	Up to 40kg/cm <sup>2</sup> g
<b>Temperature</b>	250°C
<b>Switch certification</b>	CCOE, FM, ATEX, CE (Versions applicability on request)
<b>Switch Insertion Length</b>	Up to 10000mm

# Ordering Information

## LS3000 F05-ZA-OV-VR-WQ-SI-PU-MQ

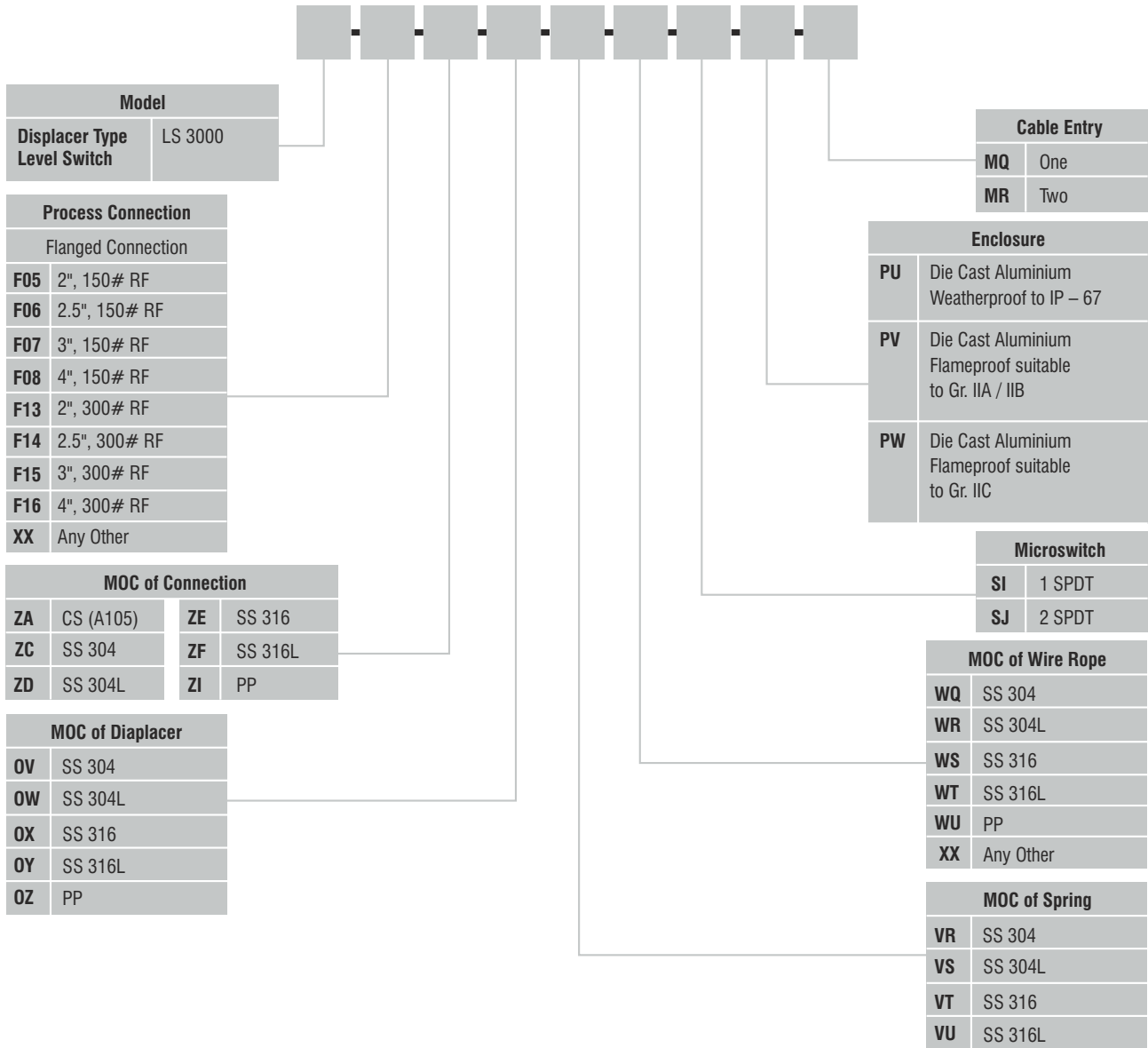

Model	
Displacer Type Level Switch	LS 3000

Process Connection	
Flanged Connection	
F05	2", 150# RF
F06	2.5", 150# RF
F07	3", 150# RF
F08	4", 150# RF
F13	2", 300# RF
F14	2.5", 300# RF
F15	3", 300# RF
F16	4", 300# RF
XX	Any Other

MOC of Connection			
ZA	CS (A105)	ZE	SS 316
ZC	SS 304	ZF	SS 316L
ZD	SS 304L	ZI	PP

MOC of Diaplacer	
OV	SS 304
OW	SS 304L
OX	SS 316
OY	SS 316L
OZ	PP

Cable Entry	
MQ	One
MR	Two

Enclosure	
PU	Die Cast Aluminium Weatherproof to IP – 67
PV	Die Cast Aluminium Flameproof suitable to Gr. IIA / IIB
PW	Die Cast Aluminium Flameproof suitable to Gr. IIC

Microswitch	
SI	1 SPDT
SJ	2 SPDT

MOC of Wire Rope	
WQ	SS 304
WR	SS 304L
WS	SS 316
WT	SS 316L
WU	PP
XX	Any Other

MOC of Spring	
VR	SS 304
VS	SS 304L
VT	SS 316
VU	SS 316L

# External Chamber Type Level Switches

*General*

## Features

- Float level switch with application upto 100 bar and 350 deg cent application
- Heavy walled floats for critical application
- CCD length defined for upto 2500mm
- Switching differential upto 10mm
- Durability defined on sealing and pressure and temperature application
- Improved reliability with dual opposed magnet design which provides snap action
- Applicable with various versions of MOC's depending on pressure and temperature, versions with Stainless and steel, hastelloy, monel, PTFE, PP, Titanium available
- Special magnet attractor to meet high temperature and pressure
- Versions with flange, screwed, welded available
- Applicable for H2S, NACE, certified
- Switch is CCOE approved and certified for IP67
- Switch certified for group IIA/IIB, IIC
- Switch enclosure at die cast alluminium and SS available
- Application with PTFE lined at special 1.6 mm thickness and PTFE floats for critical media available
- Versions with ATEX and FM certified available

Fig- 1

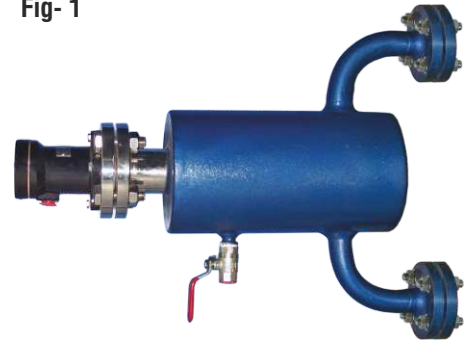

Series LS2000-SM

## Concept and Principle of Operation

*General Instruments Consortium* offers External Cage Type Level Switches for single level set point. This is trouble free, consistent and inexpensive solution to control Level in the tanks / vessels.

In this type there are two versions applicable

- External cage chamber side mounted with side mounted switch LS 2000SM
- External cage chamber side mounted with top mounted switch LS 2000MT

### Principle of operation:

1. External cage chamber side mounted with side mounted switch LS 2000SM

This type of level switch consists of fabricated external cage with inlet-outlet process connections having fixed distance. The switch assembly is mounted horizontally on the external cage as shown in figure-1.

### Application:

The external cage type level switch is mounted outside the tank / vessel which significantly reduce effect of turbulence. It also provides ease of online maintenance without impeding the process conditions.

2. External cage chamber side mounted with top mounted switch LS 2000MT

This type of level switch assembly is mounted vertically on the external cage as shown in figure-2. The external cage type level switch is mounted outside the tank / vessel which significantly reduces effect of turbulence.

Fig- 2



External cage chamber side mounted with top mounted switch LS2000

# External Chamber Type Level Switches



## Technical Specifications: Table-1 Technical data

<b>Type</b>	External Chamber Type
<b>Mounting</b>	Side Mounted on tank
<b>Switch Mounting</b>	Side / Top mounted on external cage chamber
<b>Switch Housing</b>	Die Cast Aluminium Weatherproof to IP-67 Die Cast Aluminium Explosionproof suitable for Gr. IIA, IIB Die Cast Aluminium Explosionproof suitable for Gr. IIC
<b>Switch Type</b>	Snap Acting 1SPDT/2SPDT Microswitch, 5A, 230VAC /0.5A, 24VDC
<b>Cable Entry</b>	1 no / 2 nos. of 3/4"ET(F), 1/2"NPT(F), M20x1.5(F)
<b>Process Connection</b>	Flanged in various sizes
<b>Flange MOC</b>	SS304, SS316, SS316L, Monel400, Titanium, Inconel 600, Hastelloy-C. Others on request
<b>Float/Stem MOC</b>	SS304, SS304L, SS316, SS316L, Monel400, Titanium, Inconel 600, Hastelloy-C. Others on request
<b>External cage MOC</b>	CS, SS304, SS304L, SS316, SS316L, Monel400, Titanium, Inconel 600, Hastelloy-C. Others on request
<b>Specific gravity</b>	Please specify
<b>Pressure</b>	Up to 100kg/cm <sup>2</sup> g
<b>Temperature</b>	(-20) to 350 <sup>o</sup> c
<b>Switch certification</b>	CCOE, FM, ATEX, CE (Versions applicability on request)
<b>Switch CCD Length</b>	Up to 2000mm

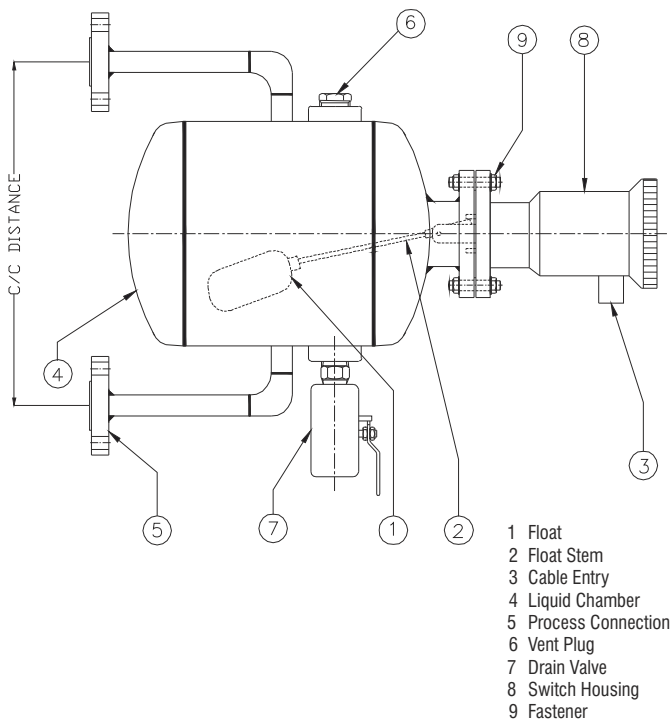

**Side Mounted Switch**

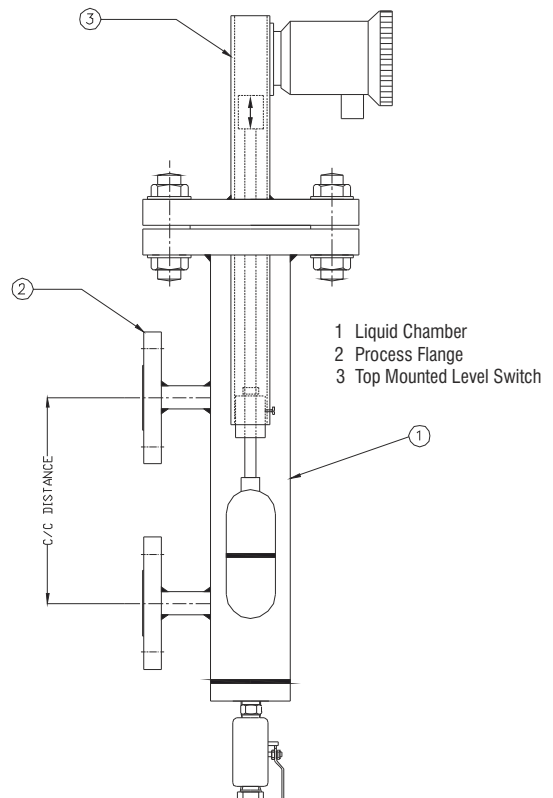

**Top Mounted Switch**

# Ordering Information

## LS2000 LS2000-SM-XX-F01-ZC-RA-QU-RU-SI-PU-MQ



Model	
External Chamber Type Level Switch	LS2000

Type	
SM	Side Mounted
MT	Top Mounted

Center to Center Distance	
XX	Please Specify

Process Connection	
Flanged Connection	
F01	1/2", 150# RF
F02	3/4", 150# RF
F03	1", 150# RF
F04	1.5", 150# RF
F05	2", 150# RF
F09	1/2", 300# RF
F10	3/4", 300# RF
F11	1", 300# RF
F12	1.5", 300# RF
F13	2", 300# RF
XX	Any Other

MOC of Connection			
ZC	SS 304	ZK	Monel 500
ZD	SS 304L	ZM	Hastelloy-B
ZE	SS 316	ZN	Hastelloy-C
ZF	SS 316L	ZO	Inconel 600

MOC of External Chamber			
RA	SS 304	RF	Monel 500
RB	SS 304L	RG	Hastelloy-B
RC	SS 316	RH	Hastelloy-C
RD	SS 316L	RI	Inconel 600

Cable Entry	
MQ	One
MR	Two

Enclosure	
PU	Die Cast Aluminium Weatherproof to IP – 67
PV	Die Cast Aluminium Flameproof suitable to Gr. IIA / IIB
PW	Die Cast Aluminium Flameproof suitable to Gr. IIC

Microswitch	
SI	1 SPDT
SJ	2 SPDT

Drain	
RU	1/2" NPT (F), Plug
RV	3/4" NPT (F), Plug
RW	1/2" Needle Valve
RX	1/2" Ball Valve
XX	Any Other

Vent	
QU	1/2" NPT (F), Plug
QV	3/4" NPT (F), Plug
QW	1/2" Needle Valve
WX	1/2" Ball Valve
XX	Any Other



# Flow Switches



## Features

- Flow control designed for upto 5000 LPM with process connection upto 2"
- Applications upto 40 bar and upto 250 deg cent available
- Flow switch with options of special bellows to cater to high flows, high pressure and high temperature
- Bellows with better hysteresis for the overall flow switch accuracy
- IBR versions available
- Applicable for H2S, NACE, certified
- Switch is CCOE approved and certified for IP67
- Switch certified for group IIA/IIB, IIC
- Switch enclosure at die cast aluminium and SS available
- Versions with ATEX and FM certified available
- Durability defined on sealing and pressure and temperature application
- Improved reliability with dual opposed magnet design which provides snap action
- Applicable with various versions of MOC's depending on pressure and temperature, versions with Stainless and steel, hastelloy, monel, PTFE, PP, Titanium available

## Concept and Principle of Operation

*General Instruments Consortium* has designed flow switches for the direct control of fluid flow in pipelines and ducts. These switches are magnetically or mechanically actuated. This is simple, reliable and economical solution to control or monitor flow in process lines. GIC offers two types of Flow Switches:

- Inline type
- Top mounted version

This is direct mounted type flow switch in pipe line. This consists of Switch assembly, Body, Bellows and Flapper. This is mounted in horizontal position. Flapper is connected to bellow assembly. When flow reaches beyond set flow the flapper moves in the direction of flow. The displacement of flapper causes actuation of the microswitch through bellow assembly. Inline type flow switch is available upto 50 NB line size and above 50 NB Top mounted is recommended. There are no vertical moving parts and is therefore maintenance free. These flow switches can be mounted in horizontal as well as vertical lines.



## Technical Specifications: Table-1 Material of Construction

<b>Displacer Flapper</b>	SS316, SS304, SS316L, SS304L, Monel, Titanium, Hastelloy, others on request PTFE lined SS, PP lined SS, PVDF lined SS, SS316, SS304, SS316L, SS304L, Monel, Titanium, Hastelloy
<b>Flange Switch enclosure Cable gland</b>	SS316, SS304, SS316L, SS304L, Monel, Titanium, cast carbon steel, Hastelloy Die cast aluminium, SS304, SS316, SS316L
<b>Bellows</b>	Brass, PBS plastic, SS316, SS304, 316L SS316, SS316L, Monel, SS304, Phosphor Bronze

## Technical Specifications: Table-2 Technical Data

<b>Flapper length</b>	12mm till 200mm depending on flow for control
<b>Flapper thickness</b>	0.15mm till 2.3 mm depending on pressure and temperature
<b>Bellow</b>	Double walled with 20, 30 and 40 convolutions and thickness of bellow more than the convolutions travel/length of the bellow
<b>Process connection</b>	½" till 2", ANSI RF, FF, 125-250AARH, DIN std DN15, 20, 25, 40, 50, socket weld, butt weld, weld neck flange in ANSI and screwed connection NPT and BSP
<b>Float</b>	Pressure design till 40 kg
<b>Flange rating</b>	max rating ANSI 600# and DN PN 100
<b>Cable gland</b>	Double compression, metal cable normal glands, ½" NPT F, ¾" ET, M20, PG 13.5, PG 16
<b>Switch</b>	SPDT, 230 VAC, 5 A or 24VDC, 0.5 A
<b>No of cable entries</b>	Max two
<b>Switch enclosure</b>	IP65, IP66, IP67
<b>Switch enclosure</b>	EExia IICT6, EExd IIA/IIB, EExd IIC
<b>Switch accuracy</b>	Max upto 1%
<b>Switch hysteresis</b>	Max upto 0.5% to 1%
<b>Switch repeatability</b>	Max upto 1%
<b>Switch certifications</b>	CCOE, FM, ATEX, CE (versions applicability on request)
<b>Flange</b>	Forged, cast versions, radiography level - 1 / 2 versions available
<b>Flow switch weight</b>	1.6 kg till 8 kg depending on configure of flow requirement
<b>Temperature application</b>	Upto 250 deg cent
<b>Pressure application</b>	Upto 40 kg/cm <sup>2</sup> g
<b>Flow in LPM in control</b>	2 LPM till 20 LPM for ½" process connection and pipe size 8 LPM to 40 LPM for ¾" pipe size 15 LPM to 190 LPM for 1" pipe size 30 LPM to 215 LPM for 1½" pipe size 40 LPM to 360 LPM for 2" pipe size 60 LPM to 700LPM for 3" pipe size 90 LPM to 1500 LPM for 4" pipe size 125 LPM to 3000LPM for 6" pipe size 200 LPM to 4000 LPM for 8" pipe size 250 LPM to 5000LPM for 10" pipe size
<b>Differential pressure</b>	75mmwc till 150 mmwc

### G A Drawing for assembly and mounting

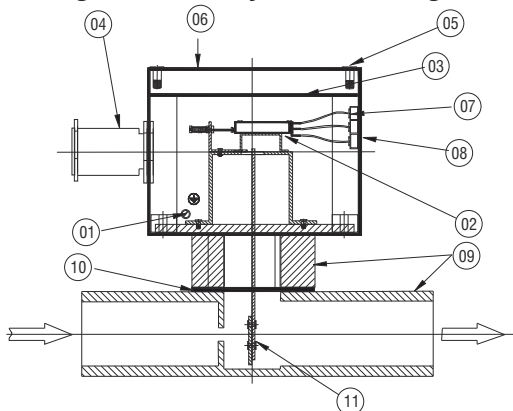

- 01 Earthing Screw
- 02 Micro Switch
- 03 Cover Gasket
- 04 Cable Entry
- 05 Cover Bolts
- 06 Enclosure Cover
- 07 Terminals
- 08 Enclosure
- 09 Body
- 10 Body Gasket
- 11 Flapper

**Inline**

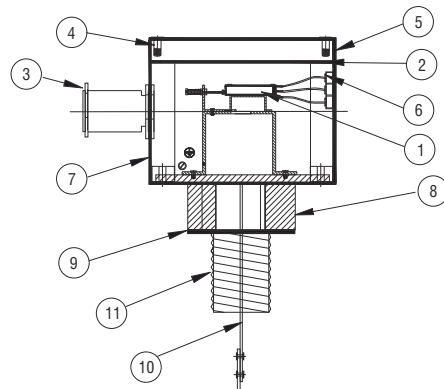

- 1 Micro Switch
- 2 Cover Gasket
- 3 Cable Entry
- 4 Cover Bolts
- 5 Enclosure Cover
- 6 Terminals
- 7 Enclosure
- 8 Enclosure
- 9 Body Gasket
- 10 Flapper
- 11 Process Conn.

**Top Mounted**

# Ordering Information

## FS IN-F01-ZA-ZC-SI-PU-MQ-Z



Type	
IN	Inline
MT	Top Mounted

Process Connection	
Flanged Connection	
F01	1/2", 150# RF
F02	3/4", 150# RF
F03	1", 150# RF
F04	1.5", 150# RF
F05	2", 150# RF
F09	1/2", 300# RF
F10	3/4", 300# RF
F11	1", 300# RF
F12	1.5", 300# RF
F13	2", 300# RF

Threaded Connection	
B04	1/2"BSP (M)
B05	3/4"BSP (M)
B06	1"BSP (M)
B07	1.5"BSP (M)
B08	2"BSP (M)
N04	1/2"NPT (M)
N05	3/4"NPT (M)
N06	1"NPT (M)
N07	1.5"NPT (M)
N08	2"NPT (M)

MOC of Body	
ZA	CS(A105)
ZB	CS(A106)
ZC	SS 304
ZD	SS 304L
ZE	SS 316
ZF	SS 316L

Cable Entry	
MQ	One
MR	Two
Z	NIL

Enclosure	
PU	Die Cast Aluminium Weatherproof to IP – 67
PV	Die Cast Aluminium Flameproof suitable to Gr. IIA / IIB
PW	Die Cast Aluminium Flameproof suitable to Gr. IIC

Microswitch	
SI	1 SPDT
SJ	2 SPDT

MOC of Flapper	
ZC	SS 304
ZD	SS 304L
ZE	SS 316
ZF	SS 316L

# Multiport Level Top Mounted Level Switches

*General*

## Features

- Float level switch with application upto 100 bar and 350 deg cent application
- Heavy walled floats for critical application
- Insertion length defined for 4500mm
- Switching differential upto 10mm
- Durability defined on sealing and pressure and temperature application
- Improved reliability with dual opposed magnet design which provides snap action
- Applicable with various versions of MOC's depending on pressure and temperature, versions with SS, hastelloy, monel, PTFE, PP, Titanium available
- Versions with flange, screwed, welded available
- Applicable for H2S, NACE, certified
- Switch is CCOE approved and certified for IP67, IP65
- Switch certified for group IIA/IIB, IIC
- Switch enclosure at die cast aluminium and SS available
- Application with PTFE lined at special 1.6 mm thickness and PTFE floats for critical media available
- Versions with ATEX and FM certified available



## Concept and Principle of Operation

This is top mounted type level switch provided single or multiple set points. It uses float that glides on the surface of liquids. This level switch consists of Terminal Enclosure, Float Stem with Reed Switches and Float with magnets assembled inside. This type of level switch can be used for single or multiple level controls. When level rises float travels with the liquid on the float stem and when it comes in contact with the reed switches located at a predetermined length of the stem, due to magnetic force reed switch changes its contact. This type of level switch is used for lengths upto 4500 mm. It is recommended to use perforated still well for lengths more than 2500 mm.

## Technical Specifications: Table-2 Technical Data

<b>Type</b>	Multiport Level Top Mounted Level Switch
<b>Mounting</b>	Top Mounted
<b>Switch Housing</b>	Die Cast Aluminium Weatherproof to IP-67 Die Cast Aluminium Explosionproof suitable for Gr. IIA, IIB Die Cast Aluminium Explosionproof suitable for Gr. IIC
<b>Switch Type</b>	Reed Switch- 0.5A, 230VAC
<b>Cable Entry</b>	1 no / 2 nos. of 3/4"ET(F), 1/2"NPT(F), M20x1.5(F)
<b>Process Connection</b>	Flanged in various sizes
<b>Flange MOC</b>	CS, SS304, SS316, SS316L, PP. Others on request
<b>Float MOC</b>	SS304, SS304L, SS316, SS316L, PP. Others on request
<b>Stem MOC</b>	SS304, SS304L, SS316, SS316L. Others on request
<b>Stopper</b>	Metal Stopper of relevant material compatible to media
<b>Specific gravity</b>	Please specify
<b>Pressure</b>	Up to 100kg/cm <sup>2</sup> g
<b>Temperature</b>	(-100) to 350°C
<b>Switch certification</b>	CCOE, FM, ATEX, CE (Versions applicability on request)
<b>Switch Insertion Length</b>	Upto 4500mm

# Multiport Level Top Mounted Level Switches

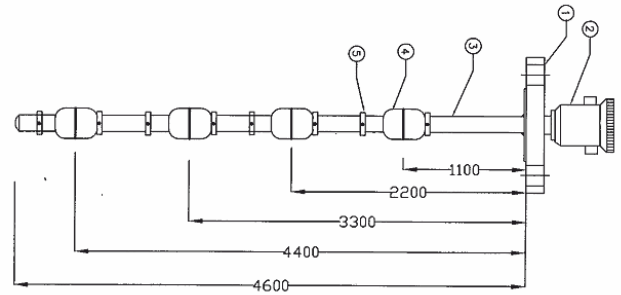
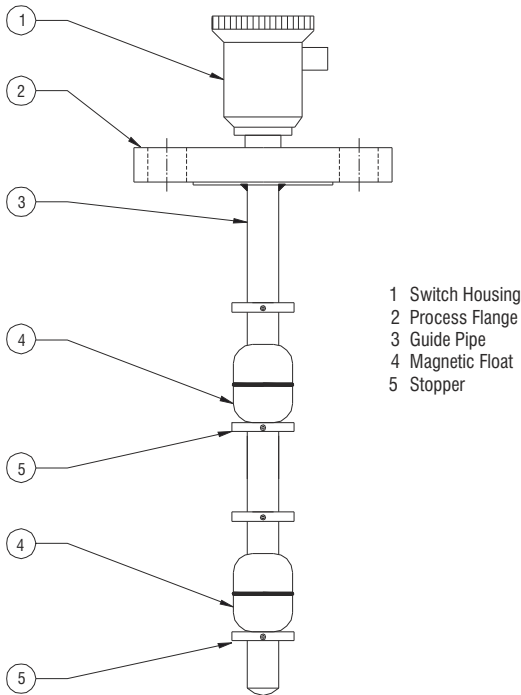

A specified application for multilevel set point in chemical industry with PTFE lined floats and float stem with 3" flange at 300# rating with pressure at 40 bar and at 140 deg cent

Four set point level switch applicable for:

- Paper industry
- Chemical industry
- Petrochemicals
- Refineries
- Fertilizers
- Food industry
- Pharma industry

Float Operated Level Switch

## Ordering Information

### LS4000 F05-ZA-YK-QU-PU-MQ

Process Connection	
Flanged Connection	
F05	2", 150# RF
F06	2.5", 150# RF
F07	3", 150# RF
F08	4", 150# RF
F13	2", 300# RF
F14	2.5", 300# RF
F15	3", 300# RF
F16	4", 300# RF

MOC of Connection			
ZA	CS (A105)	ZE	SS 316
ZC	SS 304	ZF	SS 316L
ZD	SS 304L	ZI	PP

MOC of Float	
YK	SS 304
YL	SS 304L
YM	SS 316
YN	SS 316L

Cable Entry	
MQ	One
MR	Two

Enclosure	
PU	Die Cast Aluminium Weatherproof to IP – 67
PV	Die Cast Aluminium Flameproof suitable to Gr. IIA / IIB
PW	Die Cast Aluminium Flameproof suitable to Gr. IIC

MOC of Float Stem	
YK	SS304
YL	SS304L
YM	SS316
YN	SS316L